



GigaTest Labs

Serving the Electronics Industry with Engineering Excellence

CUSTOM INTERCONNECTS

0.5mm Pitch Socket / Interconnect 0.010" Fuzz Buttons Characterization Report

March 21, 2007

**Electrical Characterization
0.05 – 10.05 GHz**

**Measurement Bandwidth
0.05 – 30.05 GHz**

Table of Contents

| Subject | page |
|--|-------------|
| Table of Contents..... | 2 |
| Summary..... | 3 |
| Objective..... | 3 |
| Methodology..... | 3 |
| Figure 1: Surrogate Packages and Socket / Interconnect..... | 3 |
| Figure 2 : Fixture..... | 4 |
| Measurement system..... | 4 |
| Equivalent-circuit model..... | 4 |
| Figure 3 - Socket / Interconnect equivalent-circuit diagram..... | 5 |
| Element definitions..... | 5 |
| Element values..... | 5 |
| Table 1 - Socket / Interconnect element values..... | 6 |
| Bandwidth Calculations..... | 6 |
| Figure 4 - Loop Thru Bandwidth measurement..... | 7 |
| Table 2 - Bandwidth PerformanceSummary..... | 7 |
| Conclusions..... | 7 |
| Appendix..... | 8 |
| Adjacent pins open..... | 9 |
| Adjacent pins shorted to ground..... | 10 |
| Adjacent pins connected together (loop-thru)..... | 11 |
| Loop-thru Bandwidth Measurement..... | 12 |
| Return loss Bandwidth Simulation..... | 13 |
| Crosstalk Bandwidth Simulation..... | 14 |
| Differential Eye-Diagram Simulation at 5Gb/sec..... | 15 |

Summary

Objective

The Custom Interconnects 0.5mm Pitch Socket / Interconnect was measured at GigaTest Labs to assess its electrical performance. A SPICE-compatible lumped element model was derived from the data. Also, its high-speed performance limits were determined.

Methodology

A custom fixture (GTL 243-GT-001 rev A1) was used by GTL which allows the use of coplanar probes to make the measurements. A second fixture was fabricated to be placed inside each Socket / Interconnect. It provides connections between the internal pins, so pairs of pins can be measured in different load conditions. This fixture is referred to as "surrogate package". Figure 1 shows a picture the surrogate package with the Socket / Interconnect array, while figure 2 shows the top and bottom of the fixture.

Figure 1: Surrogate Package (left) and a typical 10 x 10 Socket / Interconnect array (right)

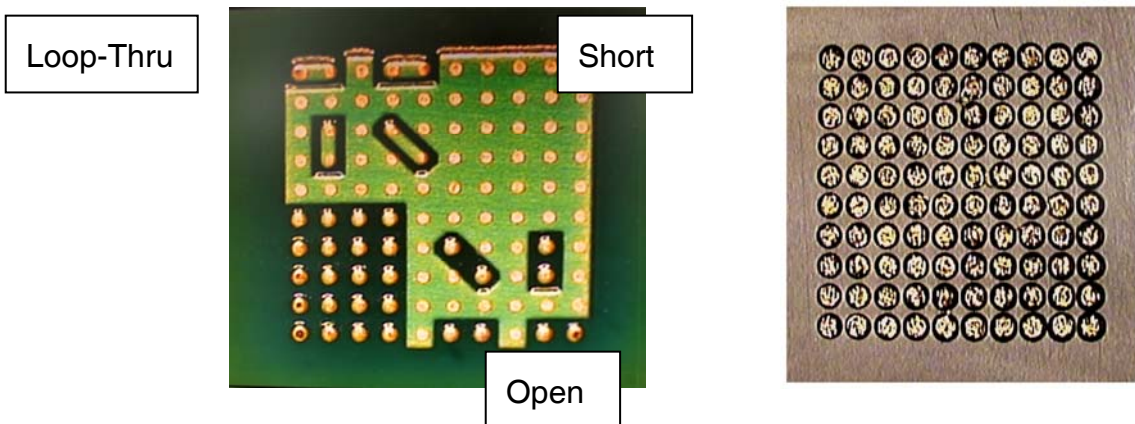

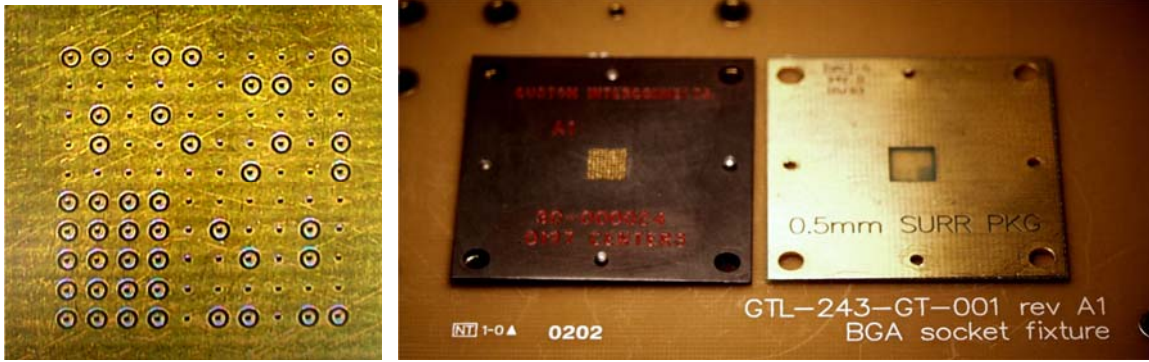

Figure 2 : Fixture showing Probe Side (left) and Socket / Interconnect Side with sample and Surrogate (right)

Measurement system

All measurements were taken using a high-frequency measurement system. This consists of a Hewlett-Packard 8510C network analyzer & GGB Picoprobes™ 200 μm pitch. The HP 8510C network analyzer is a frequency domain instrument. The measurements are taken as scattering parameters (a.k.a. s-parameters). The HP8510C has great calibration capabilities, which make it the most accurate high-frequency instrument available. For this work the short-open-load-thru (SOLT) calibration was used. The GGB Picoprobes provide a high-quality 50 Ω path from the network analyzer and cables to the DUT

Equivalent-circuit model

Figure 3 shows the topology used to model the 0.5 mm Socket / Interconnect. The measurements are taken from the PCB end, shown with ports 1 & 2. The surrogate package replaces the BGA package. The measurement standards are connected on either side of capacitor C_{21c} .

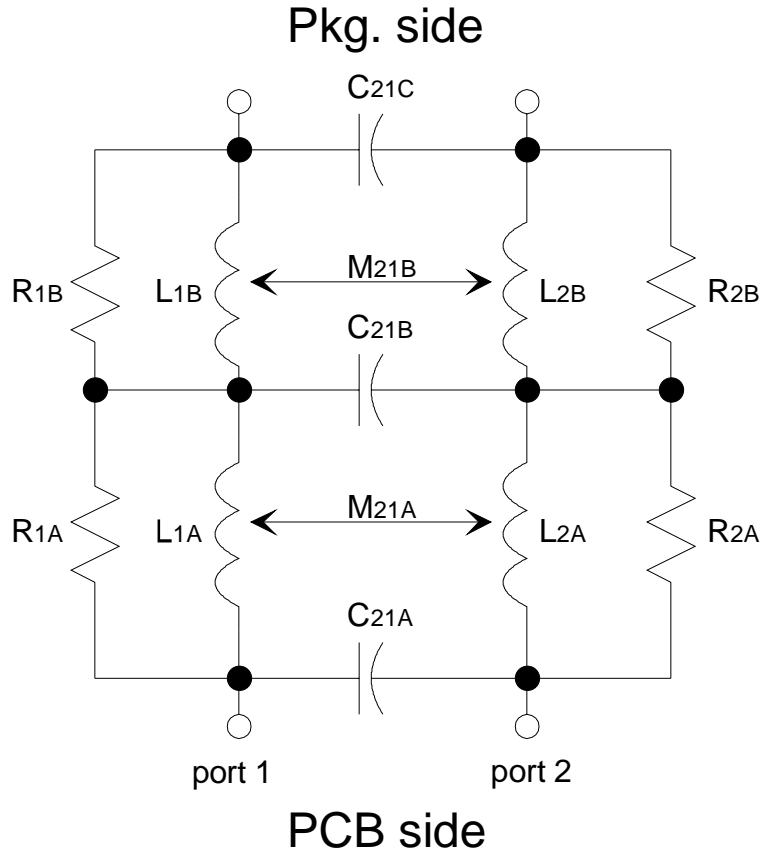

Figure 3 - BGA contactor equivalent-circuit diagram

Element definitions

- L_{1A}, L_{2A}:** partial pin self-inductance (PCB side)
- L_{1B}, L_{2B}:** partial pin self-inductance (package side)
- M_{21A}:** partial mutual-inductance between adjacent pins (PCB side)
- M_{21B}:** partial mutual-inductance between adjacent pins (package side)
- R_{1A}, R_{2A}, R_{1B}, R_{2B}:** shunt-resistance used to model high-frequency loss due to skin effect and dielectric loss
- C_{21A}:** mutual-capacitance between adjacent pins (PCB side)
- C_{21B}:** mutual-capacitance between adjacent pins (middle)
- C_{21C}:** mutual-capacitance between adjacent pins (package side)

Element values

The Socket / Interconnect model is valid from DC to 10.05 GHz. The measured and modeled transmission response agrees within 0.5 dB. A model was extracted for four

types of pins: adjacent field pins, field pins oriented diagonally and corner and edge pins.

Table 1 - Socket / Interconnect element values

| pins | L_{1a} & L_{2a} (nH) | L_{1b} & L_{2b} (nH) | M_{21a} (nH) | M_{21b} (nH) | R_{1a} & R_{2b} (Ω) |
|-----------------|---|---|---------------------------------|---------------------------------|--|
| field adjacent | 0.11 | 0.12 | 0.017 | 0.016 | 200 |
| field diagonal | 0.12 | 0.11 | 0.009 | 0.008 | 100 |
| corner adjacent | 0.18 | 0.16 | 0.030 | 0.025 | 200 |
| edge adjacent | 0.15 | 0.16 | 0.027 | 0.028 | 200 |

| pins | C_{21a} (pF) | C_{21b} (pF) | C_{21c} (pF) |
|-----------------|---------------------------------|---------------------------------|---------------------------------|
| field adjacent | 0.018 | 0.001 | 0.001 |
| field diagonal | 0.0025 | 0.0025 | 0.0025 |
| corner adjacent | 0.010 | 0.010 | 0.010 |
| edge adjacent | 0.008 | 0.011 | 0.008 |

Bandwidth Calculations

Three figures of merit are used for evaluating the bandwidth of the Socket / Interconnect:

1. The Loop Thru Bandwidth gives the frequency at which the Loss, or Attenuation of a series connection of two adjacent pins is equal to -1dB.
2. The Return Loss Bandwidth gives frequency at which the Return Loss or Reflection of a single pin in the array is equal to -10dB. This is generated by simulating the model up to 10 GHz.
3. Crosstalk Bandwidth shows frequency at which the coupling from an one pin to another in the middle of the array (field adjacent) is equal to -26dB. This is also generated by simulating the model up to 10 GHz.

Of these three, only the Loop-Thru bandwidth is determined directly from the measurements, and is valid to the highest frequency that was measured, or 30

GHz. The Return Loss and Crosstalk are simulated from the model, and are only valid to the highest frequency of the model, or 10 GHz. (See Appendix, pages 12-14).

The Loop-Thru bandwidth of the Socket / Interconnect was determined from a loop-thru measurement on two adjacent pins. The nearest row of pins was grounded (see figure 4).

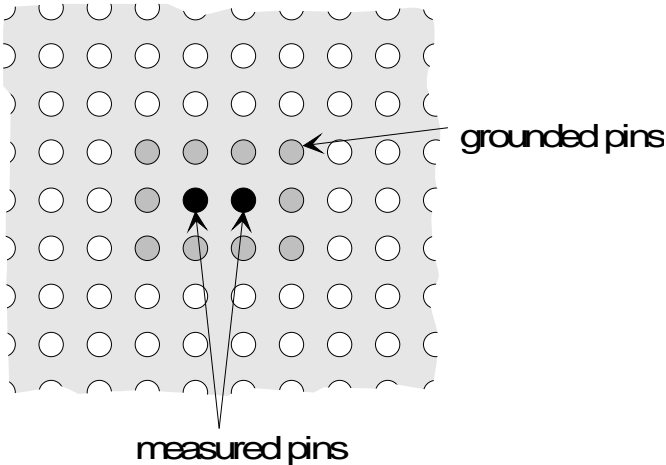

Figure 4 – Loop-Thru Bandwidth measurement

| Value | BW (freq) |
|-------------------------------|------------------|
| LoopThru Bandwidth (-1dB) | 29 GHz |
| Return Loss Bandwidth (-10dB) | > 10 GHz |
| Crosstalk Bandwidth (-26dB) | 8.7 GHz |

Table 2 – Bandwidth Performance Summary

Conclusions

The 1 dB Loop Thru bandwidth is 29 GHz, please see page 12 of the Appendix. The model bandwidth is DC-10.05 GHz, which will easily handle signals with 100 ps edges.

Appendix

The appendix shows the measured and simulated output data.

| Measured and simulated data | page |
|--|-------------|
| Open measurement..... | 9 |
| Short measurement..... | 10 |
| Thru measurement..... | 11 |
| Loop-thru bandwidth measurement (30 GHz) | 12 |
| Differential Eye-diagram at 5 Gbps | 13 |

Adjacent pins open

Measured s-parameters in blue, simulated s-parameters in red

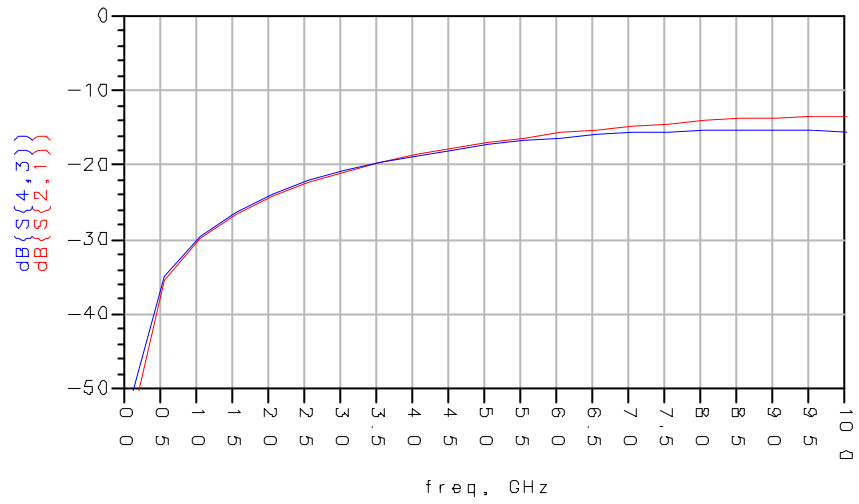
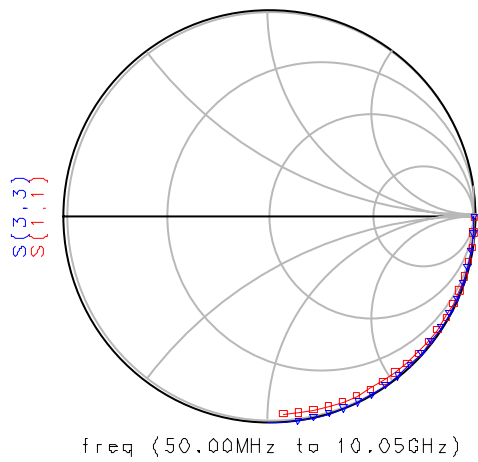

Adjacent pins shorted to ground

Measured s-parameters in blue, simulated s-parameters in red

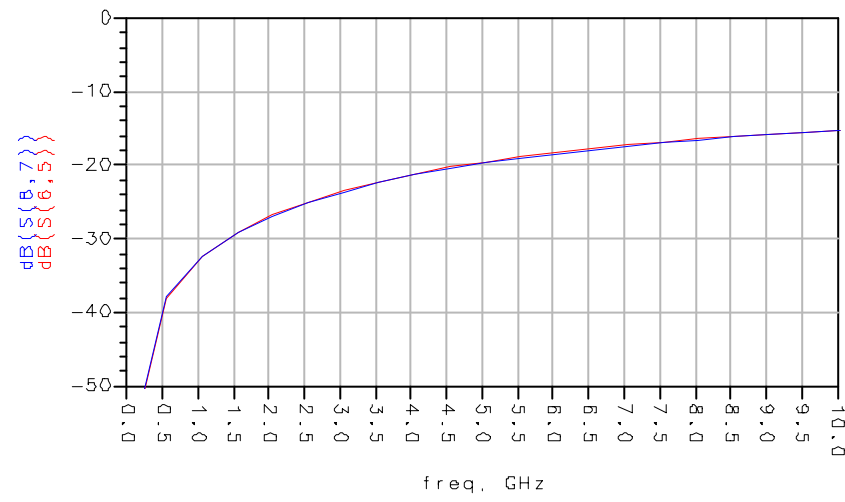
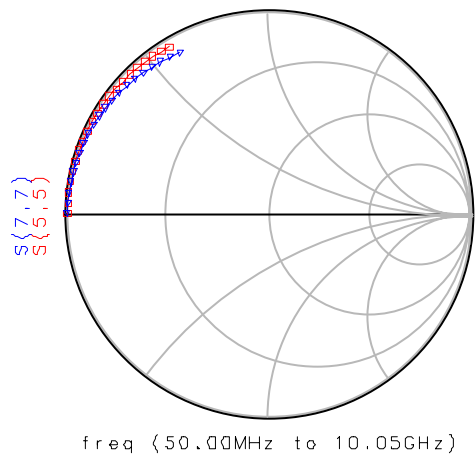

Adjacent pins connected together (loop-thru)

Measured s-parameters in blue, simulated s-parameters in red

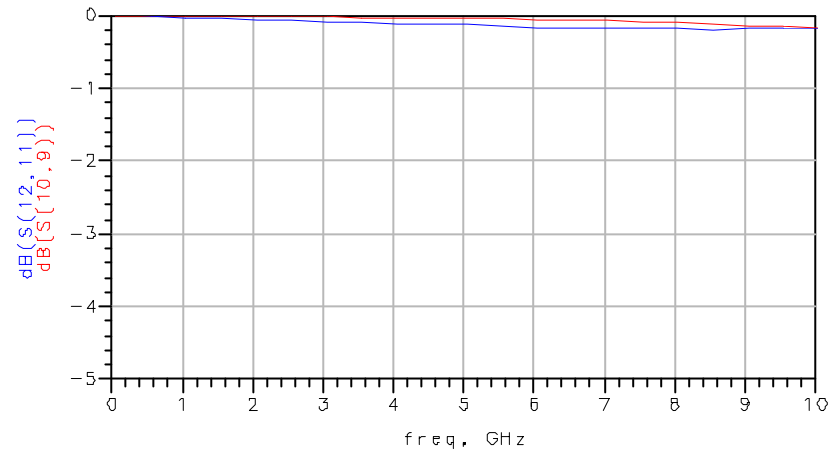
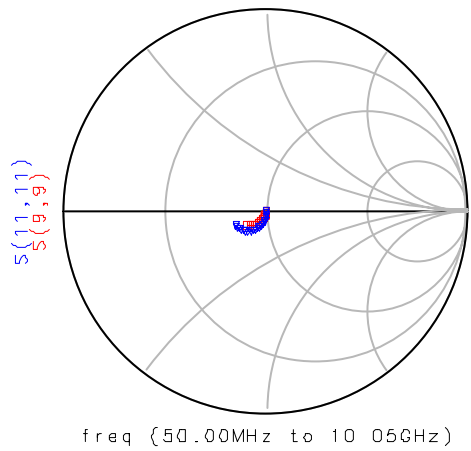

Loop-thru Bandwidth Measurement

Measured insertion loss versus frequency for two pins in series

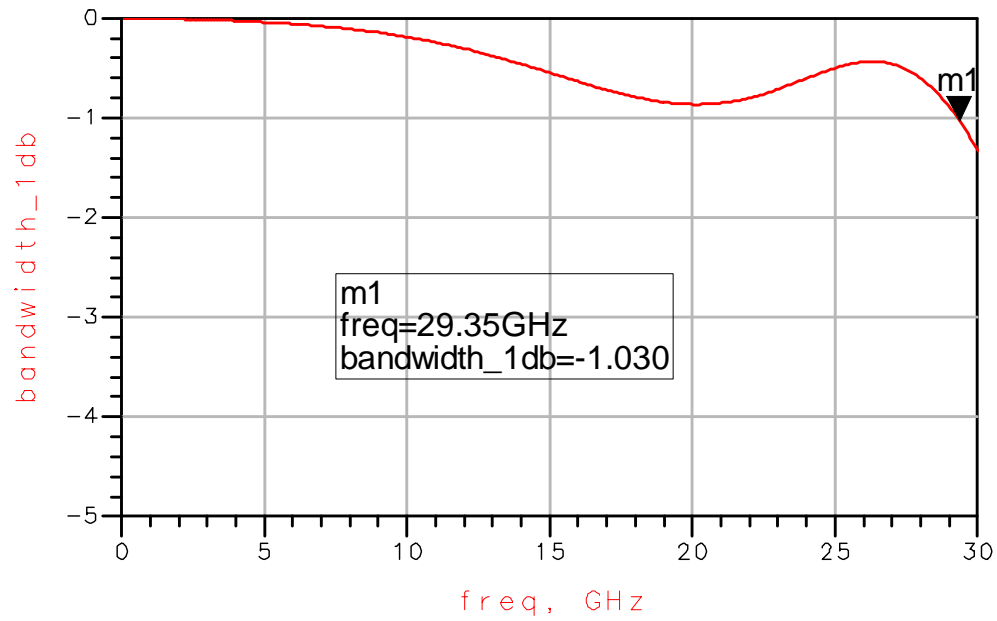

Return Loss Simulation

Simulation of Single Field Pin to 10 GHz

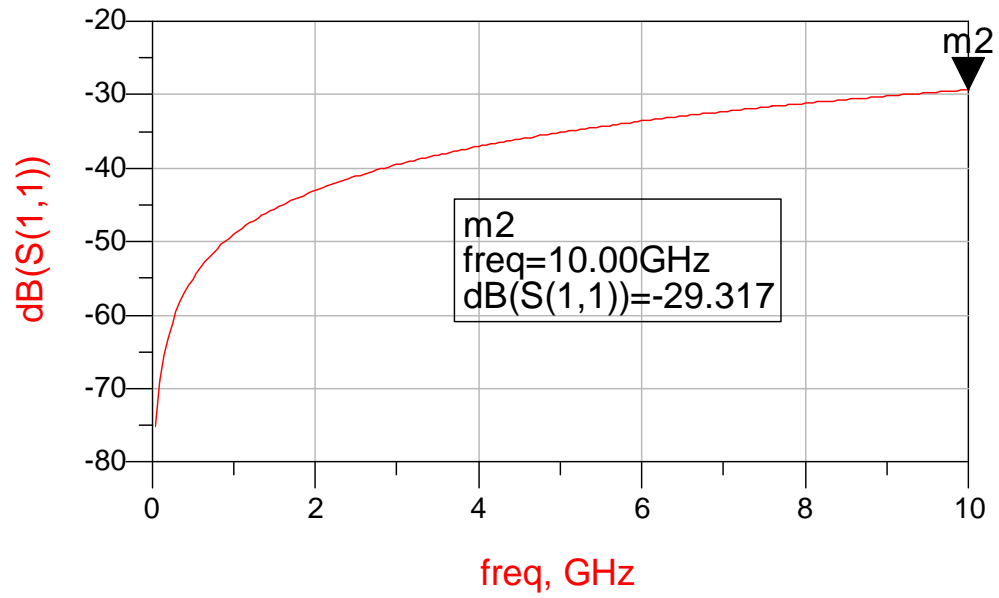

Crosstalk Simulation

Simulation of Adjacent Field Pins to 10 GHz

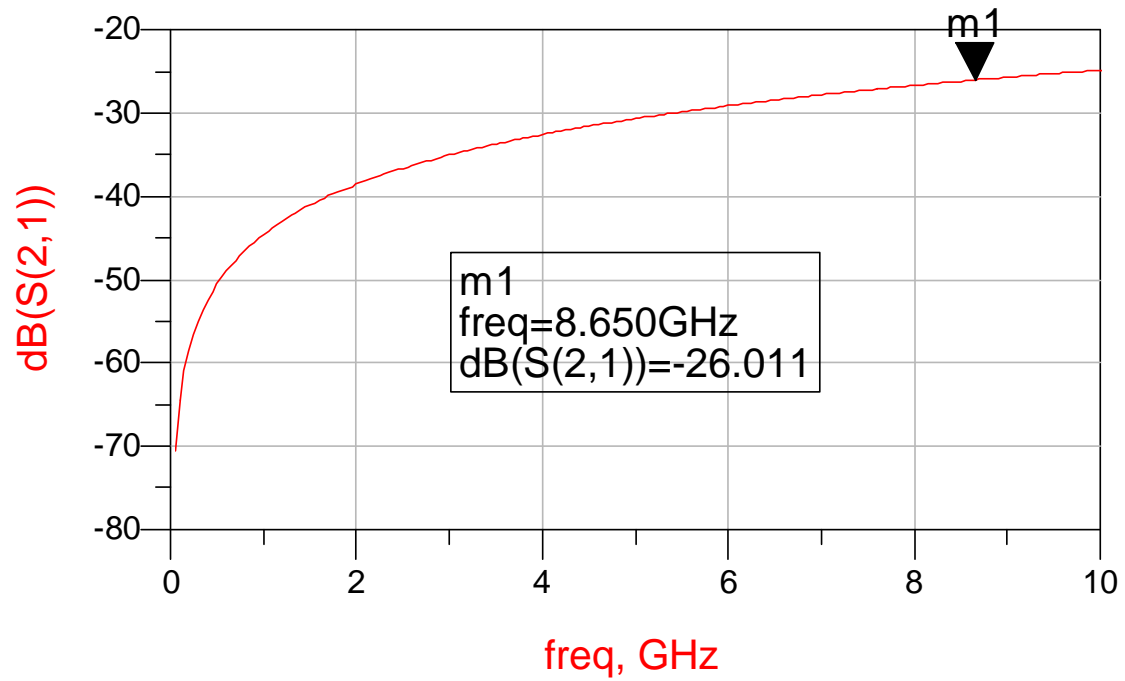

Differential Eye-Diagram Simulation at 5Gb/sec

One-way Transition on Field-Adjacent Pins

